

PLANT HOUSING, SAND FILTER & HEAT PUMP

INSTALLATION AND OPERATING INSTRUCTIONS
(to be read carefully and kept for future reference)



URBAN POOLS

GB Page 1

1. PLANT HOUSING	3
1.1 Introduction	3
1.2 Nomenclature and overview	4
1.3 Assembly	6
1.3.1 Tools required	6
1.3.2 General assembly information	6
1.3.3 Sample excavation (Urban pool 5 x 2)	6
1.4 Step by step assembly	7
1.4.1 Assembling the walls	7
1.4.2 Installing the pool mounting brackets	8
1.4.3 Installing the corner cleats	8
1.4.4 Mounting the coping support beam	8
1.4.5 Fastening the finishing trim to the ends of the wall (ref 23 on figure 2)	8
1.4.6 Assembling the plant housing	8
1.4.7 Replacing the duckboarding at the corner of the pool	9
1.4.8 Mounting the duckboarding hinge	9
1.4.9 Assembling the flaps	10
1.4.10 Mounting the coping on the plant housing	10
1.4.11 Locking mechanism	10
2. SAND FILTRATION GROUP	11
2.1 Introduction	11
2.2 Nomenclature	11
2.3 Assembly and installation	11
2.3.1 Installation on an existing Urban pool	12
2.4 Operation	13
3. HEATING WITH A HEAT PUMP	14
3.1 Introduction	14
3.2 Hydraulic installation	14
3.3 Wiring, operation and maintenance	16
4. GUARANTEE CONDITIONS	17
4.1 Plant housing	17
4.2 Sand filtration group	17
4.3 Heat pump	17

1. PLANT HOUSING

1.1 Introduction



Figure 1

The plant housing is a compartment that fits against the wooden structure of your Urban pool at the corner closest to the skimmer. It is made of wooden slats, identical to that of the pool, to ensure seamless integration. It can be fitted to all Urban pool models.

In the event that your Urban pool is set deeper than 25 cm into the ground, installation of the plant housing is mandatory to ensure that the filtration circuit remains accessible. It can house the pool's peripheral drainage relief well, the filtration electrical panel, the automatic cover control panel, and the sand filtration group if this option was selected. In fact, the plant housing access hatch can be locked with a key, this allows compliance with the French standard NF C15-100 despite the presence of items powered by a 230V supply at a distance of less than 2m from the pool.

In the case of above-ground installations, the plant housing embellishes your pool by concealing the hydraulic circuit, the filter, the pump, the electrical panel and the automatic cover motor.

! *Nota bene 1:* If you do not assemble the plant housing immediately, the package must be properly stored, without being unpacked, in a cool well ventilated location, or failing that, sheltered from bad weather and the sunlight. The aim is to prevent deformation of the wooden elements that would make assembly more difficult. Deformation of the wood could only be caused by failing to properly store the package after delivery.

! *Nota bene 2 :* In the event that the pool is installed in-ground or partially in-ground, the wooden structure of the plant housing is subject to the same precautions as the wooden structure of the Urban pool itself:

- Application of a foundation grade dimpled drainage sheet to the outside of the walls on the portion that will be buried.
- Application of a product to prevent wood rot to any edges cut during installation.

IN THE EVENT OF A CLAIM, YOU MUST INCLUDE THE PLANT HOUSING TRACKING NUMBER THAT CAN BE FOUND ON THE BACK OF THESE INSTALLATION INSTRUCTIONS.

1.2 Nomenclature and overview

NO.	QUANTITY	DESCRIPTION	COMMENT	KIT	
1	1	Wall slat 1750x78x45 mm, male	Base of external wall	Wood kit	
2	9	Wall slat850x145x45 mm, male/female	Wall connected to pool no. 1		
3	1	Wall slat669x78x45 mm, male	Base of wall connected to pool no. 2		
4	8	Wall slat669x145x45 mm, male/female	Wall connected to pool no. 2		
5	17	Wall slat1750x145x45 mm, male/female	External wall		
6	1	Wall slat1750x70x45 mm, female	Top of external wall no. 2		
7	1	Wall slat850x70x45 mm, female	Top of wall connected to pool no.1		
8	1	Wall slat1750x137x45 mm, female	Top of external wall no. 1		
9	1	Wall slat1418x137x45 mm, female	Duckboarding support structure		
27	1	Wall slat669x137x45 mm, female	Top of wall connected to pool no.2		
12	3	Double width pine coping 1750x145x28 mm	Large duckboarding		
19	8	Double width pine coping 630x145x28 mm	Small duckboarding, not including the lock slat		
15	1	Double width pine coping 630x145x28 mm pierced to mount the lock	Small duckboarding with lock		
21	1	Double width pine coping 238x70x28 mm plant housing corner	Duckboarding corner element to replace that delivered with the pool		
23	6	Pine finishing trim 1295x70x45 mm, H=1330 mm	Wall edge trim		
16	2	Cleat 450x55x20 mm	Assembly of the hinged access hatch (long section)		
17	1	Cleat 270x55x20 mm	Assembly of the hinged access hatch (long section)		
22	2	Cleat 732 x 55 x 20 mm	Assembly of the hinged access hatch (short section)		
24	3	Cleat 1300x55x20 mm	Slat interlock retainer		
10	2	Shoe	Fixing the duckboarding support slat		
11	48	Torx screw 6x30 SS A2	Fixing the shoes, the lock striker support bracket		Screw kit
13	90	Wood screw 5x40 SS A4	Fixing the corner cleats, assembly of duckboarding		
none	30	Torx screw 4x35 SS A2	Fixing the access hatch hinges		
none	18	Domed head nails 2.8 × 60 SS A2	Fixing the trim		
14	5	Hinge	Access hatch hinge	Hardware kit	
18	1	Lock + seal + locking ring + latch (separate)	Access hatch lock		
20	1	Striker and latch	Access hatch locking mechanism		
25	1	Support bracket 1250 mm solid/ housing	Fixing the housing along the length of the pool	Wood kit	
26	1	Support bracket 1250 mm indented/ housing	Fixing the housing across the width of the pool		

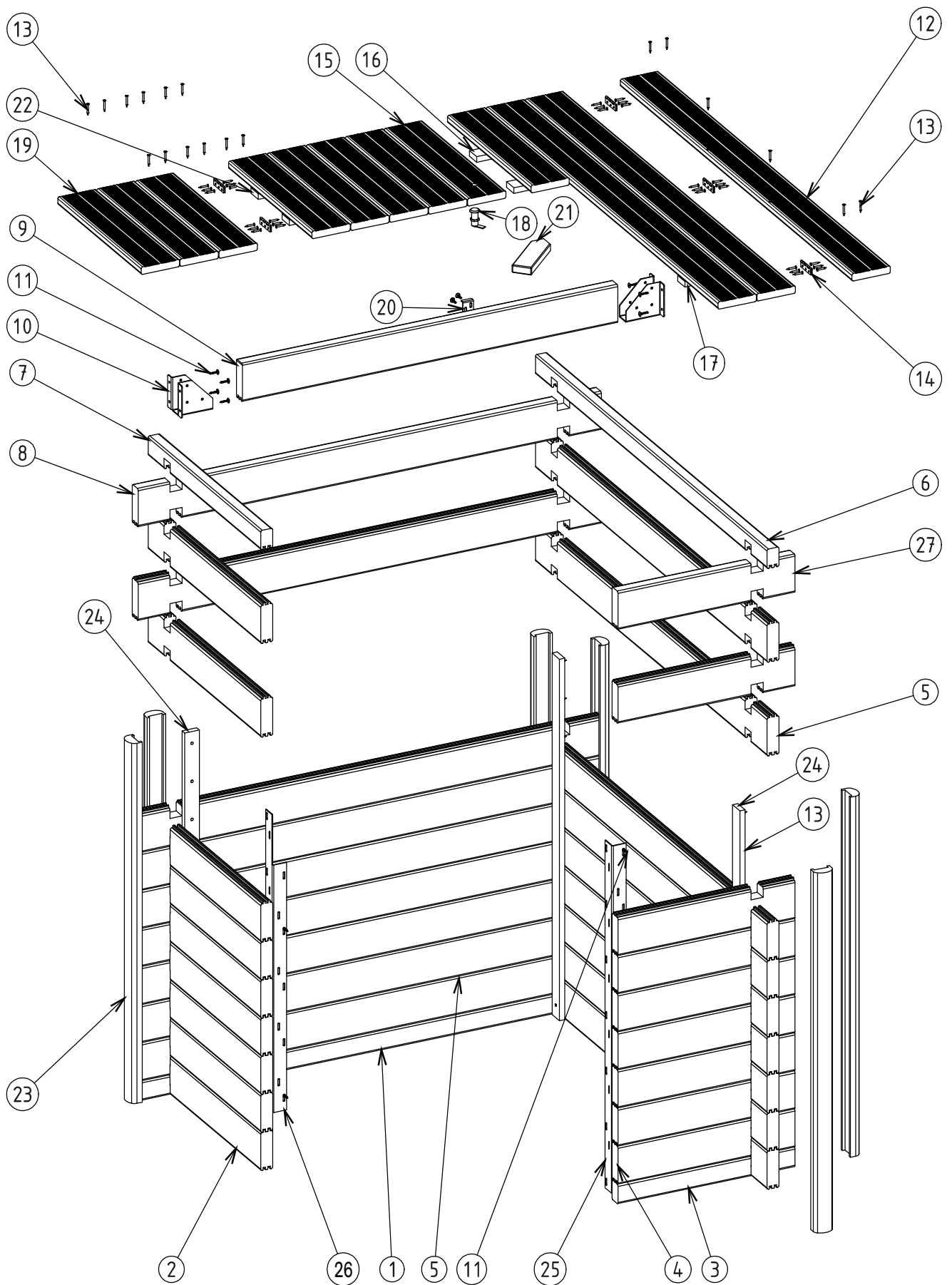

Figure 2

1.3 Assembly

Time required: approximately 2 hours with 2 people

1.3.1 Tools required

- Martyr slat (use the one provided with the wooden structure)
- Mallet
- Tape measure
- Electrical drill
- Crosshead bit and torx bit, 30 and 25 mm
- 2, 3 and 4 mm diameter drill bits to pre-drill screw holes
- Spanner

The plant housing should be assembled after the wooden pool structure is mounted and the filtration system is installed (unless the heat pump option was selected, see the chapter dedicated to this topic).

1.3.2 General assembly information

If you intend to install your Urban pool fully or partially in-ground, take the pool footprint into consideration when excavating.

Whatever the installation configuration, we recommend that you create a slab large enough to contain both the pool surface area and that of the housing to optimise the stability of the structure.

! NOTA BENE : in the case of an in-ground (fully or partially) configuration, the peripheral drain and the relief well should be installed before the slab is poured, especially if the relief well will be located inside the plant housing.

1.3.3 Sample excavation (Urban pool 5 x 2)

If you are adding the plant housing to an existing Urban pool installed above-ground, you can extend the slab. In any case, make sure that the housing support structure is level with, and continues directly from, the slab and that the support structures are solid and will remain stable over time.

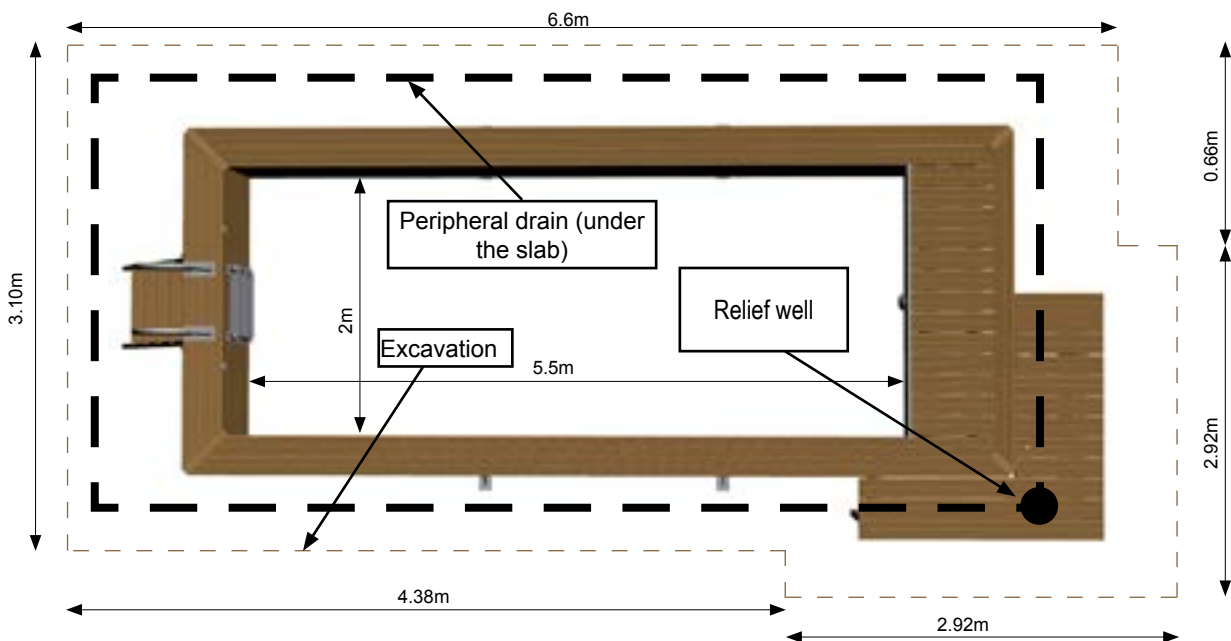

Figure 3

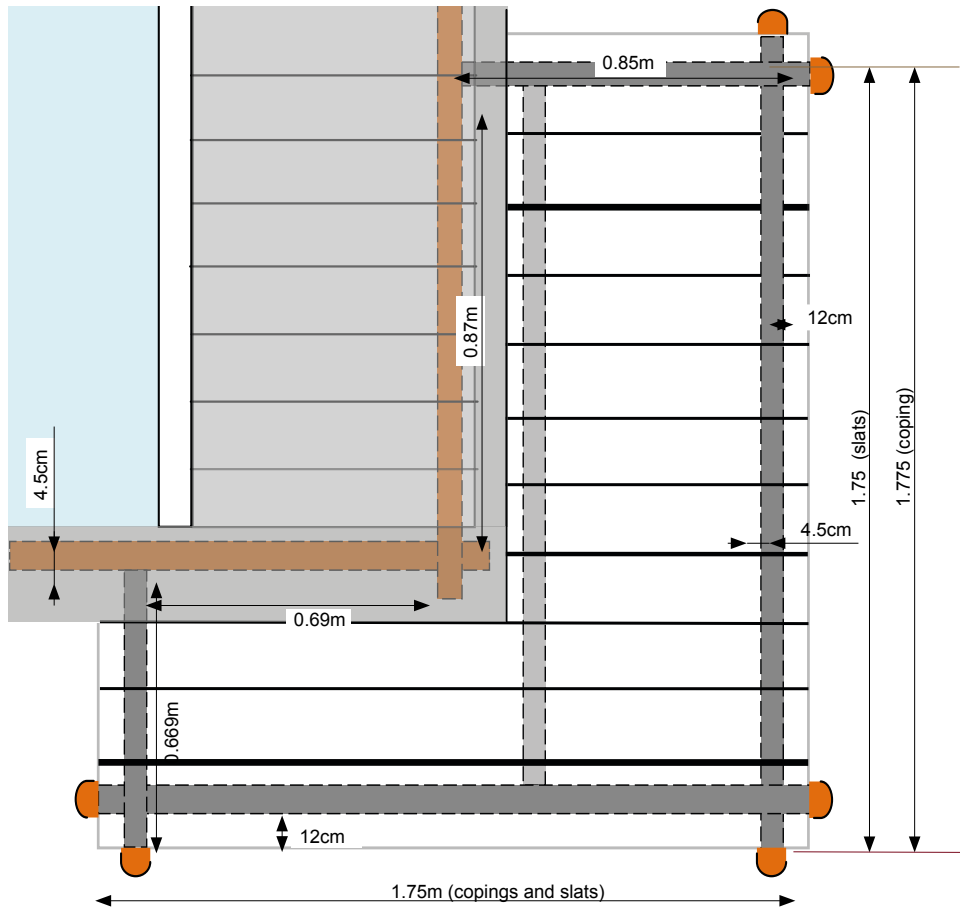

Figure 4

1.4 Step by step assembly

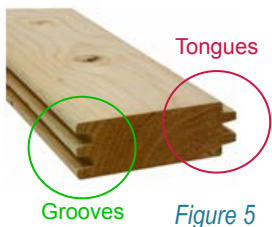

Figure 5

Assemble the structure exactly where the pool is to be installed because, due to its significant weight, it will not be possible to move the plant housing once it has been built. See the dimensions in figure 4

1.4.1 Assembling the walls

Male-female slat



Figure 6

To assemble the structure, start at the base and work your way up, slat row by slat row.

The wall slats fit together by means of tongues (male) and double grooves (female) that run the length of the slats, and a system of notches located 12 cm from the ends of the each slat.

Tongues should face upwards and grooves should face up.

After assembling the first row of slats on the ground, position the two end slats against the pool exactly where they should be positioned. (see the dimensions in figure 4).

Check that the corners are square. Assemble the walls, taking care to ensure that the slats are fully engaged in each other.

1.4.2 Installing the pool mounting brackets

These two brackets are used to attach the housing to the pool. The indented bracket (ref 26) connects the plant housing to the pool width that holds the skimmer, the full bracket (ref 26) connects the housing to the adjacent length.

The indented stile of the indented bracket is screwed to the wall of the pool.

Attach each mounting bracket to the interior, flush with each of the two free ends (see figure 2) using torx screws, 6x30 (18 screws per bracket).

1.4.3 Installing the corner cleats



Figure 7

Fasten a cleat (ref 24 of figure 2) in each of the 3 vertical interior corners of the plant housing. Use 30 wood screws 5x40.

Place the widest cleat against the external wall of the plant housing, and fasten the cleat at the centre of each of the slats on this wall using wood screws, 5x40, working from the inside of the plant housing.

In the corner of the housing comprising 2 external walls, the cleat may be attached to either one or the other.

1.4.4 Mounting the coping support beam

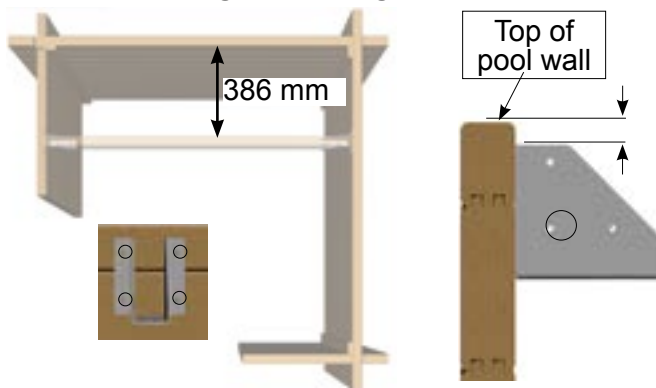

Figure 8

Screw each of the two beam support (ref 9 on figure 2) fastening shoes (ref 10 on figure 2) at the following locations using 4 torx screws, 6x30, per shoe :

Next, position the beam in the shoes.

Fasten the beam in position in the shoes using a torx screw, 6x30, inserted into a hole on the side of the shoe.

1.4.5 Fastening the finishing trim to the ends of the wall (ref 23 on figure 2)



Fasten a strip of finishing trim to ends of each wall. To do this use 3 round head nails, 2.8 x 60: one at the top, one in the middle and one at the bottom of each finishing strip.

Make sure that the points are centred on the wall slats to avoid splintering.

N.B. : the finishing strip should not extend above the top of the wall

1.4.6 Assembling the plant housing

Assembly is done by fastening the brackets to the pool wall slats using torx screws, 6 x 30 (2 screws per bracket, one at the top, one at the bottom). Avoid placing the screws too close to the edge of the slat edge to avoid splitting the wood. **BE CAREFUL NOT TO USE THE WRONG SCREW** to avoid piercing the liner.

1.4.7 Replacing the duckboarding at the corner of the pool



The corner piece enclosed with the wood pack of your Urban pool has a straight edge that will leave an empty triangular space after the plant housing coping is installed.

To avoid this, replace this part with that enclosed with the plant housing (ref 21 on figure 2), that has a pointed edge.

1.4.8 Mounting the duckboarding hinge

To provide access to the interior of the plant housing, the duckboarding has a hatch with two moving flaps that must be assembled. The hatch is fitted with a lock to secure the plant housing.

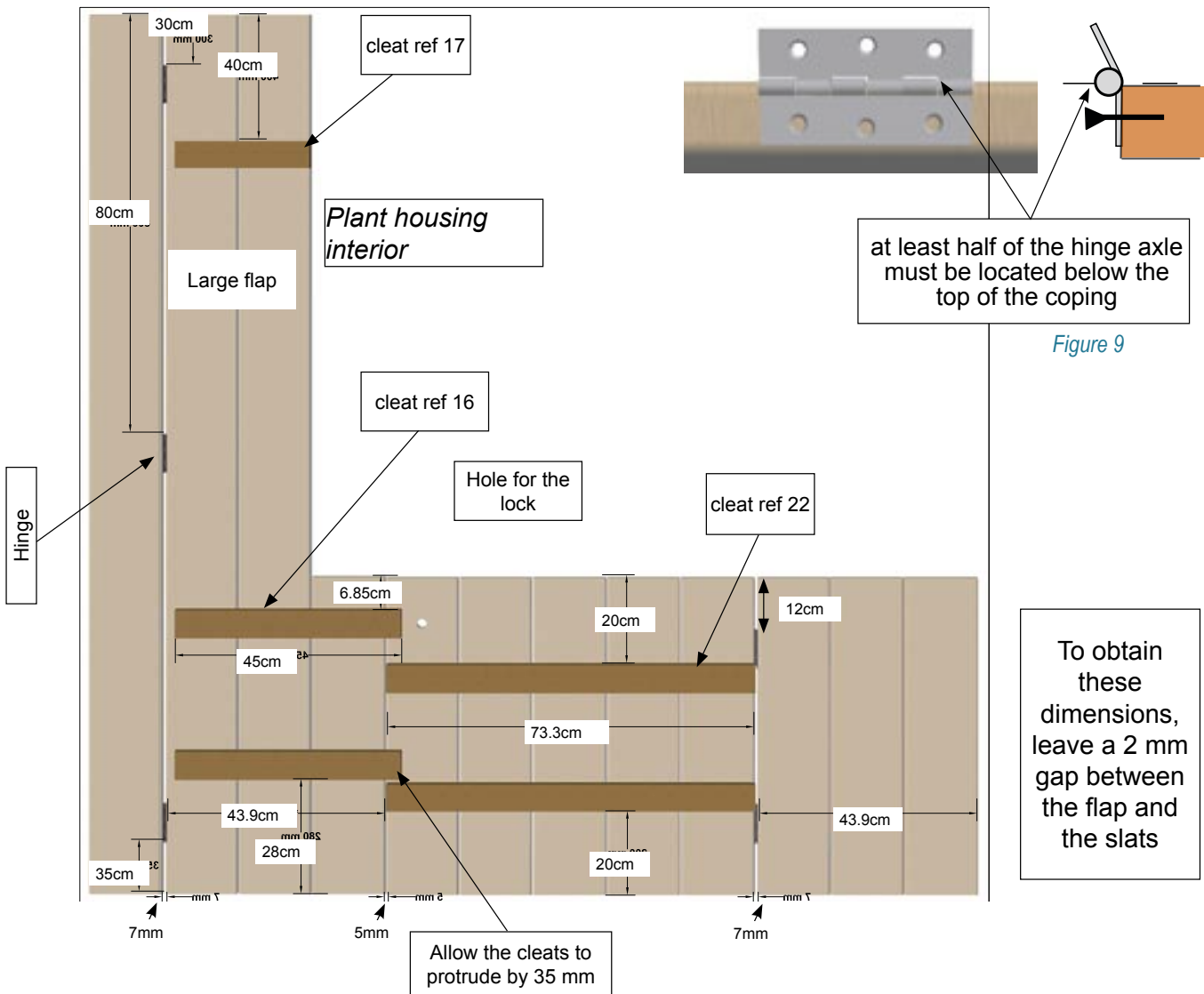

Figure 10 - Assembly of the duckboarding

- Using 3 torx screws, 4x35, per hinge, screw 3 hinges to the edge of a duckboarding slat that is 1.75 m long (ref 12 in figure 2) at the locations indicated in figure 10 (pre-drill the holes where necessary using a 2 mm drill bit) taking care to follow the instructions in figure 9. This coping slat will be mounted on top of the wall at the edge of the housing (see figure 4).
- Using 3 torx screws, 4x35, per hinge, screw 2 hinges to the edge of a duckboarding slat that is 63 cm long (ref 19 in figure 2) at the locations indicated in figure 10.

1.4.9 Assembling the flaps

For each hatch flap, fasten the coping slats together using a cleat fastened underneath the slats. Use 2 wood screws, 5x40, per cleat and per slat.

1. The small flap is comprised of 5 coping slats 63 cm long, it includes the slat that features a hole for mounting the lock (ref 15 figure 2): fasten two cleats, length 73 cm, (ref 22 in figure 2) under the coping slats, taking care to respect the dimensions and 2 mm gap between the copings shown in figure 10.
2. Build the large moving flap using two 1.75 m long coping slats and one 63 cm long slat:
 - a. Fasten two 45 cm cleats (ref 16 in figure 2) under the 3 coping slats, allow the cleats to extend 3.5 cm beyond the slats on the side of the 63 cm coping slat. Respect the dimensions and 2 mm gap between copings shown in figure 10;
 - b. Next, fasten the 27 cm cleat under the two 1.75 m copings.

1.4.10 Mounting the coping on the plant housing

1. Position the large moving flap on top of the plant housing, leave a 2 mm gap between the moving flap and the pool coping.
2. Place the 1.75 m coping slat that holds the hinges upside down on the flap, fasten the hinges to the edge of the flap.
3. Once the hinges have been attached, fasten this coping slat to the ends of the walls using two wood screws, 5 x 40, inserted from the top side of the coping.
4. Position the small moving flap on the housing, taking care to respect the 2 mm gaps indicated in figure 10.
5. Place the 63 cm coping slat bearing the 2 hinges upside down along the lip of this flap to attach the hinges to the edge of the flap.
6. Once the hinges have been attached, fasten this coping slat to the top of the walls using wood screws, 5 x 40, and do the same for the last two coping slats using 4 screws per slat.

N.B. : MAKE SURE THAT THE SCREW HEADS DO NOT STICK UP FROM THE COPING TO AVOID WOUNDING THE FEET OF PEOPLE USING THE POOL.

1.4.11 Locking mechanism

The hatch locking system comprises, a cam to be mounted on the end of the lock barrel, and a striker to be mounted on the duckboarding support slat.



Figure 11

1. Unscrew and remove the hex nut from the lock barrel.
2. Remove the hex screw located at the end of the barrel.
3. Thread the o-ring onto the lock barrel.
4. Push the lock barrel fully into the 20 mm hole provided for that purpose in the end of the lock slat.
5. Working from underneath, replace the hex nut. Take care to tighten the nut correctly.
6. Place the cam at the end of the barrel, it should be oriented toward the support slat when the lock is closed. Tighten the hex screw well.
7. Using 2 torx screws, 6 x 30, fasten the striker to the vertical surface of the support slat, make sure that it is oriented towards the lock such that the cam is located under the edge of the striker when locked.

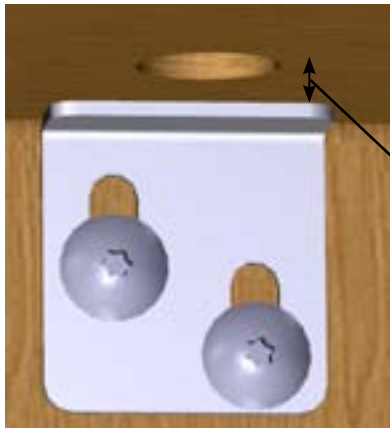

25 mm if the shoes holding the beam are located at the positions indicated in figure 8

Figure 12

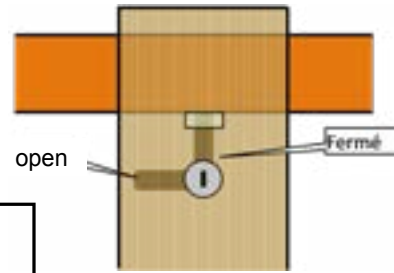

Figure 13

2. SAND FILTRATION GROUP

2.1 Introduction

This option replaces the skimmer cartridge filter and pump delivered as standard.

Sand filters are more practical to clean than cartridge filters, and their retention capacity (the quantity of impurities that they retain before becoming saturated) is much higher. In addition, the pump has a higher flow rate than that provided as standard with the pool, this means that impurities are removed more quickly, and the length of the filtration cycle can be reduced.

The «sand filter» option can only be supplied independently of the plant housing, for aesthetic reasons, but above all for safety reasons: in fact, the filtration group runs off a 230 V power supply, and must therefore be housed in a location that can be locked if it is closer than 3.5 m to the pool, as is the case. The plant housing must therefore be kept locked at all times and the key must be kept out of the reach of children.

2.2 Nomenclature

- P-GFI 400 filtration group, 4 m³/h, grey, the nomenclature of which is broken down in the installation instructions provided with it
- One 25 kg bag of filtration sand 0.6/1.25
- 1 section of semi-rigid tubing, outer diameter 38 mm, 1.22 m long for the suction side
- 1 section of semi-rigid tubing, outer diameter 38 mm, 1.85 m for the return side
- 1 set of fittings :
 - 2 reducer cone 63 x 50 x 32 mm
 - 2 TORRO 40-60 circlips
 - 1 ¼ turn double-union valve, solvent, for pipes with a 38 mm outer diameter
 - One 30 cm section of rigid PVC pipe, outer diameter 32 mm
 - 2 hose tails 50 mm solvent/ 38 mm

2.3 Assembly and installation

Assembly of the filtration group is described on pages 1 to 6 of the installation instructions provided with it.

Once the group has been assembled, it is installed and connected to the pool as follows:

Preamble: if your pool is fitted with the plant housing option, the filtration group should be raised to provide easy access to the hand grip on the multi-port filtration valve and the pump lid without climbing into the housing. Place a stable solid support (not supplied) under the base of the filtration group to raise the group approximately 50 cm.

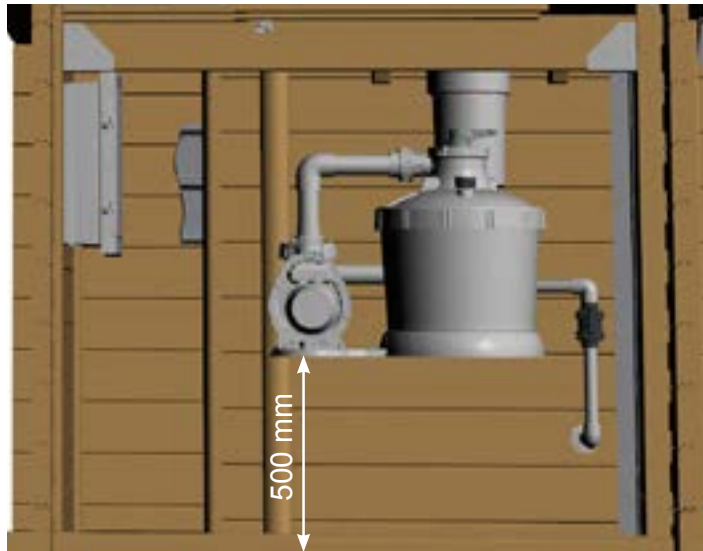

Figure 14

2.3.1 Installation on an existing Urban pool

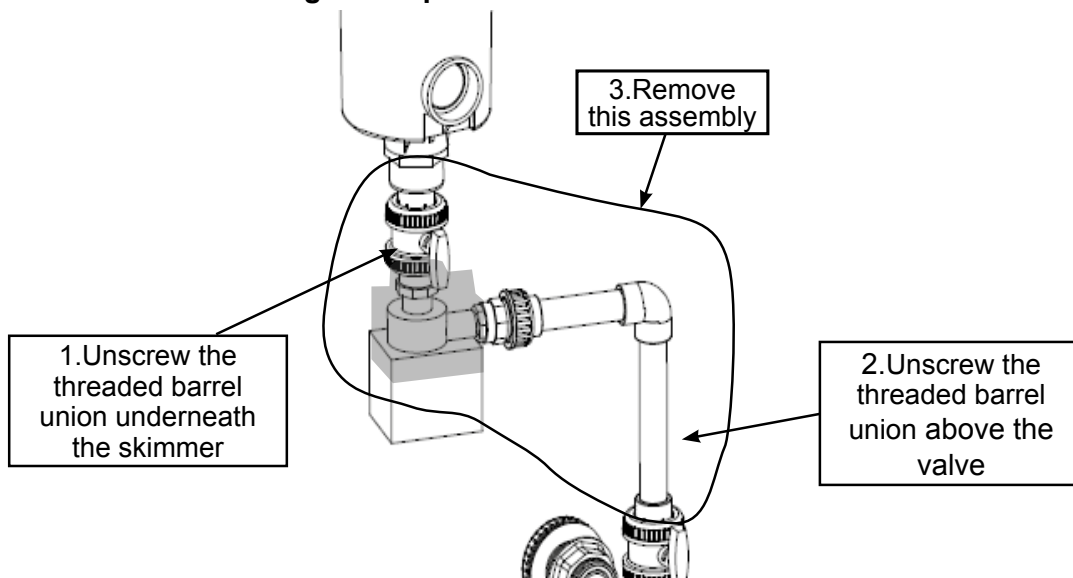

Figure 15

Set aside the two barrel unions of the $\frac{1}{4}$ turn valves, and build two assemblies as described below:

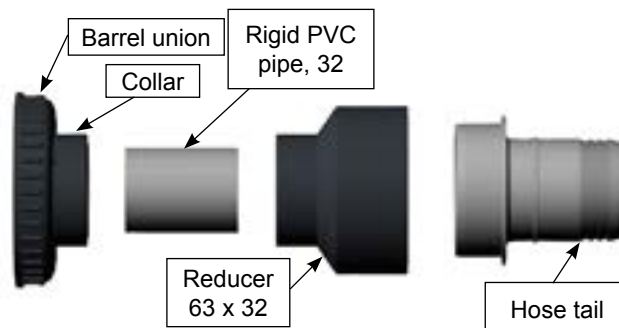

Figure 16

- insert a collar into the threaded union of the $\frac{1}{4}$ turn valve,
- Glue a 4 cm length of rigid PVC pipe, diameter 32 mm, into the collar,
- follow this with a 63 x 50 x 32 reducer cone,
- lastly, add a 50 x 38 hose tail

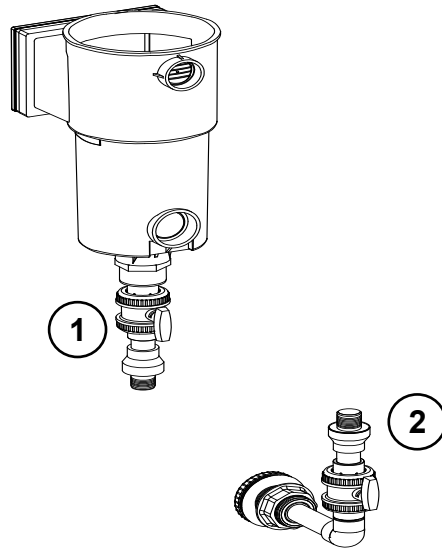

Figure 17

Screw one of these assemblies to the valve on the skimmer side, and the other to the valve on the return side.

Next, use a length of semi-rigid suction hose tubing to connect the skimmer outlet to the pump suction port (1),

Use a length of semi-rigid return tubing to connect the filter outlet port to the pool return fitting (2).

Secure the tubing in position on the unions using TORRO circlips.

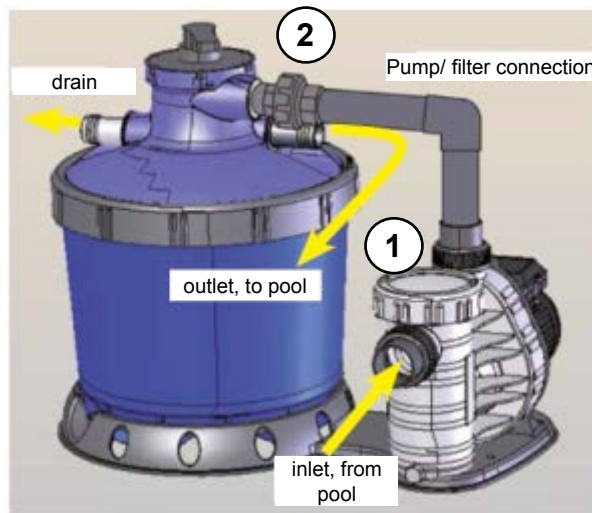

Figure 18

The drain outlet is used to channel waste back-wash water, and to drain the pool.

Excess return and suction tubing can be used to drain water from the plant housing: create a hole in the housing to thread the tubing through; treat the edges of the drilled hole if the housing is located in-ground.

2.4 Operation

Remember to remove the skimmer cartridge before starting up the sand filter, the Net'Skin can be left in position.

Operation of the multi-port valve, as well as instructions for carrying out a back wash, is described in the filtration group operating instructions.

3. HEATING WITH A HEAT PUMP

3.1 Introduction

To achieve an adequate flow rate through the heat pump, this option can only be used with a hydraulic pump more powerful than that supplied as standard with your Urban pool, that is, with the sand filter + housing option.

The heat pump may not be installed in the plant housing because it must be placed outdoors where air flow is not restricted.

To ensure electrical safety, the heat pump must be located no closer than 3.5 m to the pool, on a solid and stable horizontal support (ideally a concrete slab). It should be fixed in position using its feet.

3.2 Hydraulic installation

The heat pump should be connected on the pool's filtration hydraulic circuit on a by-pass loop; the principal is set out in the heat pump installation instructions.

For this, a by-pass kit is enclosed with the heat pump, it comprises the following elements:

DESCRIPTION	QUANTITY
TORRO 40/60 circlips protection	2
F/F equal Tee, solvent, 50 mm	2
Pot of Griffon WDF-05 glue, 125 ml	1
Double union 1/4 turn valve, 50M x 50M	2
PVC slit valve, diameter 50 mm	1
0.30 m length of rigid PVC pipe, 10 bar, 50 mm	2
Set of 2 unions and o-rings, Ø50mm, Fairland	1
TORRO 40-60/12 W4 A2 circlips	2
Hose tail 50x38, black	2
Straight fixed hose tail, 50 x 45, grey (not used for the Urban pool)	2
Tubing LD grey D38 , 4.5 m	2
Connection	1

To feed the two 38 mm diameter semi-rigid pipes (suction and return) through the plant housing, it will be necessary to make two holes in one of the walls (40 mm diameter hole) at positions suited to the selected location of the heat pump and the Urban pool configuration (in-ground, partially in-ground or above-ground). Cut-outs must be treated against rot if the housing is installed partially or fully in-ground.

Follow these recommendations when glueing pipes, unions, valves with PVC glue:

- The two mating surfaces should be sanded first using fine grain sand paper;
- The edges should be deburred and chamfered;
- Apply glue generally to the mating surfaces;
- Immediately after applying the glue, fit the parts together without rotating one in the other.

Perform the following steps:

- Close the skimmer and return ¼ turn valves;
- Proceed with assembly of the filtration group as described in the previous chapter, but do not mount the tube that connects the sand filter outlet to the return (otherwise, undo the TORRO circlips and remove the pipe joining the filter outlet to the return fitting)
- Assemble the heat pump by-pass module as follows :

REFERENCE	NUMBER	DESCRIPTION	
1	1	Fairland union and o-rings (set of 2)	
2	6	PVC pipe Ø50 PN10	
3	2	1/4 turn double union valve, solvent, 50 mm open	
4	2	Equal tee, female, solvent, 50 mm	
5	2	Hose tail	
6	1	Slit valve,PVC, Ø50 mm	

- Cut two 61 mm lengths of 50mm diameter semi-rigid tubing
- Apply glue and insert each one fully into the lateral outlet of two rigid tees
- Insert a 50 mm slit valve between the two tees, and glue it to the sections of rigid tubing (push the pipes in fully): the two tees must be perfectly parallel (lay them flat during this step)
- Glue a 50 / 38 hose tail to the same side of each tee
- Cut four 60 mm sections of 50 mm diameter rigid pipe
- Glue these sections to each side of the two ¼ turn 50mm valves, make sure to insert the pipe fully into the valves
- Glue a Fairland union to each of the ¼ turn valve outlets (do not forget to slide on the barrel unions before glueing)
 - Connect this module to the heat pump.
 - Fit the two 38 mm diameter semi-rigid pipe sections onto the hose tail outlets, use the TORRO circlips and their protection
 - Connect the tube mounted on the heat pump inlet to the filter outlet
 - Connect the tube mounted on the heat pump outlet to the return.

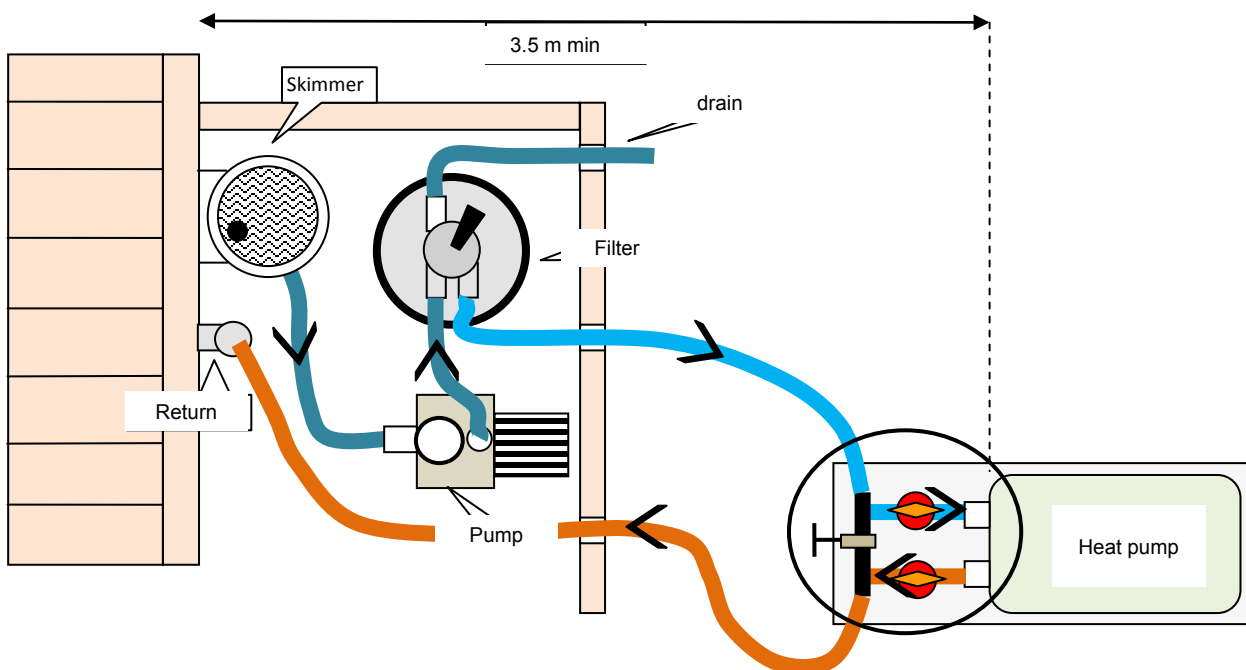

Figure 19

In any case (even if your pool is installed above-ground), we recommend that you bury the pipes running between the heat pump and the housing to prevent damage caused by exposure to sunlight or damage caused by garden tools (mowers, edge trimmers, etc.) and freezing of the water during winter. Under the ground, the pipes should not be in contact with sharp stones, ideally they should be run on a bed of sand, and then covered with sand before backfilling.

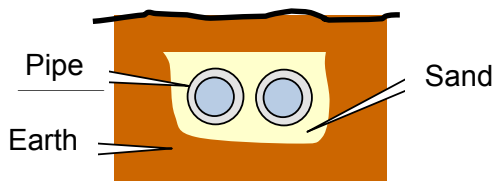

Figure 20

It is important to leave a little slack when running pipes underground, and to run them along the bottom of the excavation. Piping should descend and then remount vertically in order to avoid stress loading on the glued fittings.

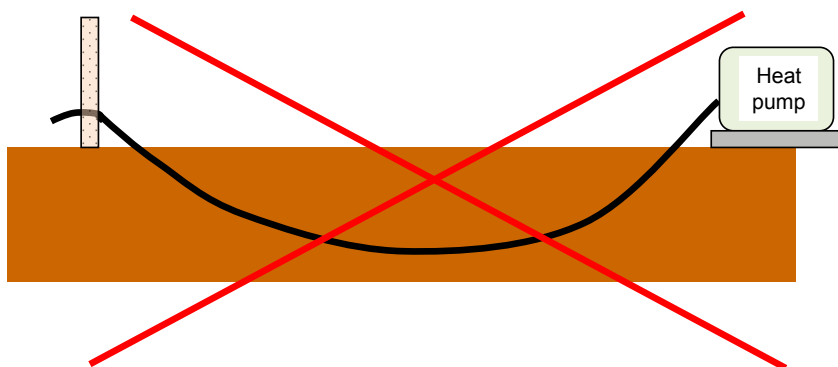

Figure 21

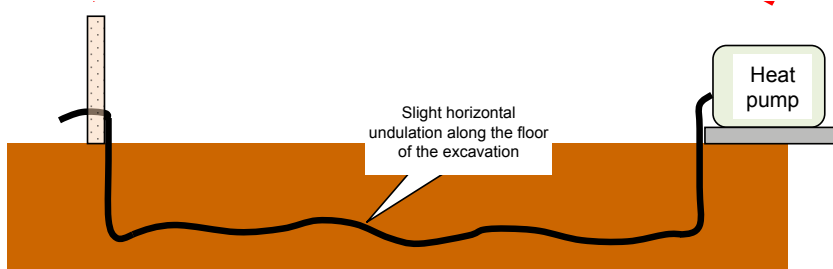

Figure 22

Do not force semi-rigid pipe to follow a sharp corner, this could damage the pipe. The minimum radius of curvature is 8 cm.

The heat pump power cable should also be run in a protective sheath.

Take care to follow the heat pump maintenance and winterizing recommendations (notably concerning drainage) set of the heat pump installation and operating instructions..

3.3 Wiring, operation and maintenance

Refer to the heat pump installation instructions

4. GUARANTEE CONDITIONS

The guarantees below only apply if all installation, maintenance and operating recommendations have been followed.

4.1 Plant housing

SUBJECT AND SCOPE OF THE GUARANTEES	DURATION OF THE GUARANTEE AS OF THE DATE OF PURCHASE
Rotting of the wood	10 years

4.2 Sand filtration group

SUBJECT AND SCOPE OF THE GUARANTEES	DURATION OF THE GUARANTEE AS OF THE DATE OF PURCHASE
Motor operation	2 years
Filter tank leaktightness	5 years
Leaktightness of the tank unions, filter drain, operation of the multi-port valve	2 years
Leaktightness of the semi-rigid tubing	2 years

4.3 Heat pump

SUBJECT AND SCOPE OF THE GUARANTEES	DURATION OF THE GUARANTEE AS OF THE DATE OF PURCHASE
	2 years, repair in the factory

Notes

A series of horizontal dotted lines for taking notes, starting from the top right of the 'Notes' header and extending across the page.

Notes

A series of horizontal dotted lines for taking notes, starting from the top right of the 'Notes' header and extending across the page.



CERTIFICAT DE QUALITE

CHAÎNE DE CONTRÔLE PEFC

Société **PROCOPI**
35650 LE RHEU

N° Chaîne de contrôle **FCBA/12-01382**

La chaîne de contrôle de l'entreprise ci-dessus désignée est en conformité avec les exigences PEFC* en vigueur.

Ce certificat est délivré selon le référentiel PEFC de la chaîne de contrôle des bois de FCBA MQ CERT 11-360.

Périmètre	Méthode utilisée
Fabrication et distribution d'équipements bois pour piscines Sur le site de Pleumeleuc	Transfert en pourcentage moyen

Ce certificat atteste la vérification de la chaîne de contrôle, fondée sur un contrôle permanent. Il ne peut préjuger d'évolutions ou de décisions qui seraient prises en cours d'année. La liste des entreprises sous certification est disponible sur les sites Internet : www.fcba.fr et <http://registor.pefc.ca>

cofrac



CERTIFICATION DE PRODUITS INDUSTRIELS

ACCREDITATION
N°5-011
PORTÉE
RESPONSABLE SUR
WWW.COFRAC.FR

* annexes 15 et 16 du schéma français de certification forestière, traduction des annexes PEFC ST 2002 : 2010 et PEFC ST 2001 : 2008 du document technique international du PEFC Council.



INSTITUT TECHNOLOGIQUE

99, avenue de Saint-Mandé
75012 Paris
Tél : +33 (0)1 49 19 49 19
Fax : +33 (0)1 43 40 85 65
www.fcba.fr

N° de Certificat
0226/2012
Date : 13 février 2012
Valable jusqu'au 01/02/2017

LE RESPONSABLE CERTIFICATION
Alain HOCQUET

Numéro de série

